

Liftakselventil (LACV)



463 084 031 0
463 084 041 0 med fittings

Niveauventil



464 006 002 0
464 006 100 0 med højdestop
464 006 102 0 med fittings



Montage kit.
433 401 003 0

Koblingshoved med integreret filter



Forsyningsluft

952 201 012 0
952 201 015 0 med fittings



Styreluft

952 201 011 0
952 201 014 0 med fitting og test nippel

Kombilæsnerventil (PREV)



Produkt nummer	Med fittings	Skilt	Test nippel
971 002 900 0	X	✓	X
971 002 902 0	X	X	X
971 002 910 0	✓	X	X
971 002 911 0	✓	X	X
971 002 912 0	✓	✓	✓

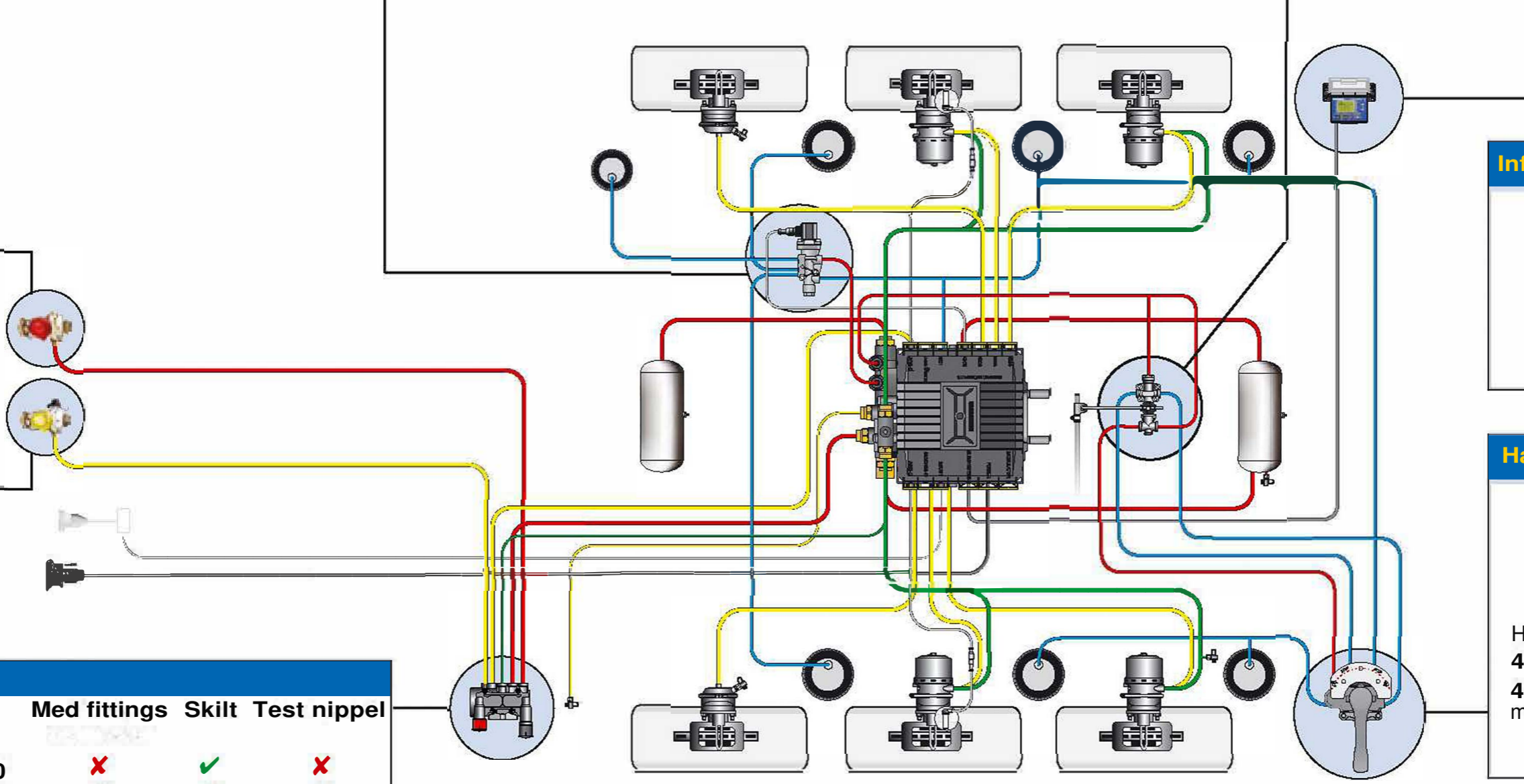

Standard med Alm. affjedring

Information system



SmartBoard
446 192 110 0

Hæve/Sænkeventil



Hæve/Sænkeventil
463 032 020 0
463 032 220 0 med fittings

Trailer EBS E Modulator	Produkt nummer	System	Understøtter mekanisk Affjedring	Understøtter ECAS affjedring	Antal GIO porte	PEM	Fittings	Slange størrelser Forsyning Affjedring	
	480 102 030 0	Standard, 2S/2M	X	X	4	X	X	Ø 16 X 2	Ø 8 X 1
	480 102 031 0	Standard, 2S/2M	X	X	4	✓	✓		
	480 102 032 0	Standard, 2S/2M	X	X	4	X	✓		
	480 102 033 0	Standard, 2S/2M	X	X	4	✓	✓	Ø 15 X 1.5	Ø 12 X 1.5
	480 102 034 0	Standard, 2S/2M	X	X	4	✓	X		
	480 102 060 0	Premium, max 4S/3M	✓	✓	7	X	X		
	480 102 061 0	Premium, max 4S/3M	✓	✓	7	✓	✓	Ø 16 X 2	Ø 8 X 1
	480 102 062 0	Premium, max 4S/3M	✓	✓	7	X	✓		
	480 102 063 0	Premium, max 4S/3M	✓	✓	7	✓	✓	Ø 15 X 1.5	Ø 12 X 1.5
	480 102 064 0	Premium, max 4S/3M	✓	✓	7	✓	X		

Diagnose Trailer EBS E



Diagnose interface med USB kabel
446 301 022 0



Diagnose kabel
446 300 361 0



Forbindelses adapter ISO 7638 med CAN stik
446 300 360 0

Option 2



Diagnose interface med serial stik
446 301 021 0



CAN converter
446 300 470 0



Forbindelses adapter ISO 7638 med CAN stik
446 300 360 0

Option 3



Diagnose interface USB eller serial



Diagnose kabel
446 300 348 0



Diagnose stik med gul prop (kun Premium ECU)
449 611 ... 0

Premium med ECAS affjedring

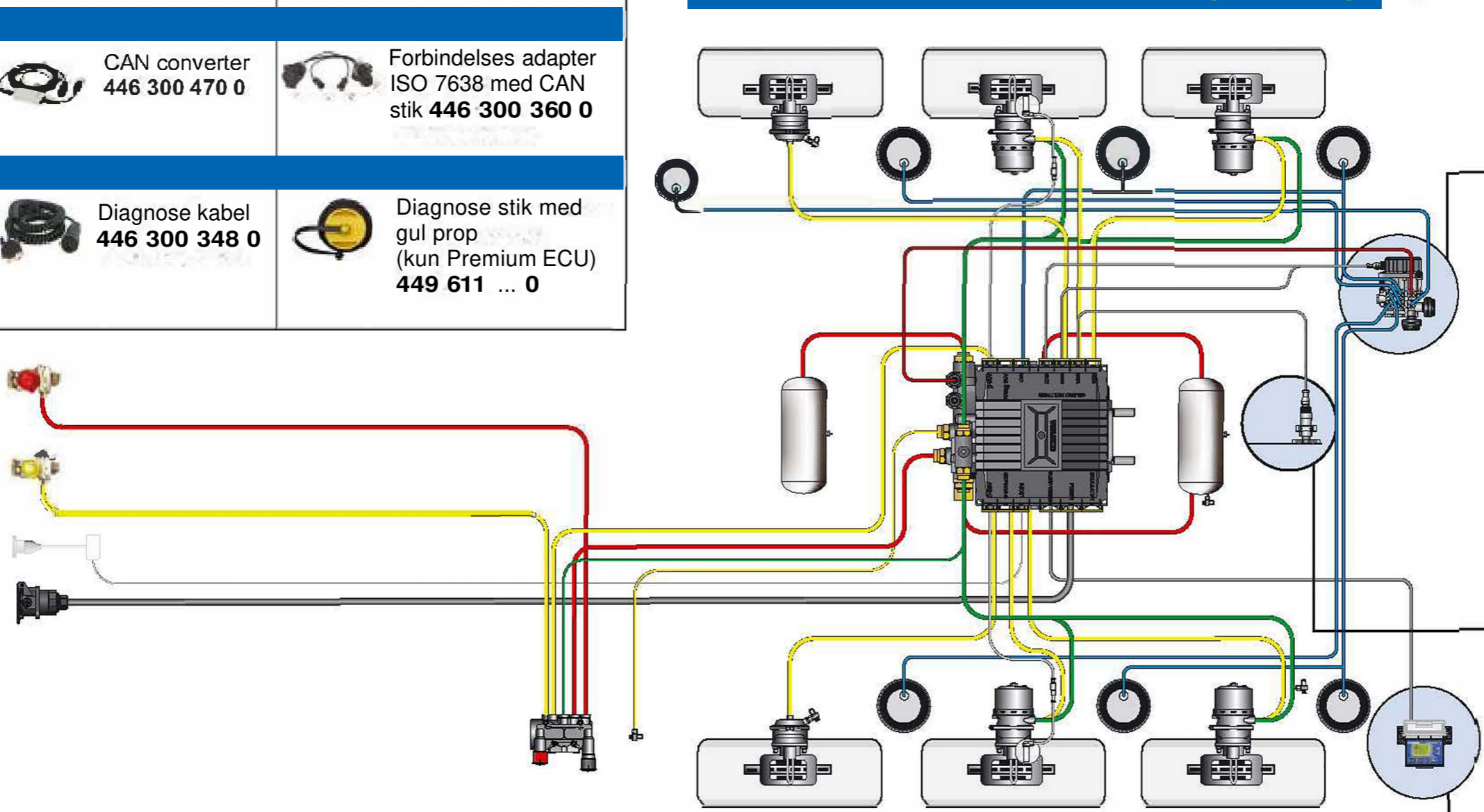

ECAS magnetventil



472 880 030 0 med højde kontrol



472 905 114 0 med højde og liftaksel kontrol

ECAS niveausensor



Sensor
441 050 100 0



Arm f. sensor
441 050 718 2



Montage kit
433 401 003 0

Affjedrings kontrol



Fjernbetjening
446 056 25X 0 forvogn og trailer kontrol fra førhuset.
Påkrævet WABCO CAN2 ECU



ECAS kontrol box
446 156 010 0 med højde kontrol
446 156 011 0 med højde og liftaksel kontrol



ECAS fjernbetjening
446 056 116 0 med højde kontrol
446 056 117 0 med højde og liftaksel kontrol



SmartBoard
446 192 110 0